

# Stoves4U

Best value whiteware in NZ

Phone 0274470431 for our latest stock.



## Fisher & Paykel Electronic Clock Instructions

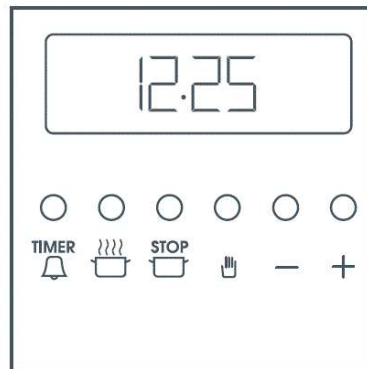

Congratulations for purchasing your refurbished stove.

Based in Wellington New Zealand Stoves4U are dedicated to reducing the impact our life has on the environment.

We recycle, repair, up-cycle and resell stoves. By buying one of our recycled Stoves you are ensuring the hazardous contaminants such as the copper, cadmium, hexavalent chromium, flame retardants, lead and plastics are kept from landfills or other locations where they could impact the local environment.

Reuse ensures that no further carbon is emitted into our atmosphere to manufacture and transport whiteware which can lengthen the life of our landfills. There are few items in a stove that cannot be repaired or replaced. Reuse, refurbishment and right-to-repair is strong in our business model.

Recycling creates a closed loop in the economy, gives these stoves a new lease on life and promotes local employment. All this and you'll have a company that backs up the sale with a carefully inspected and repaired stove so you'll have our 90 day warranty.

# Stoves4U

Best value whiteware in NZ

Phone 0274470431 for our latest stock.



## Westinghouse 3 Button Clock Instructions



Congratulations for purchasing your refurbished stove.

Based in Wellington New Zealand Stoves4U are dedicated to reducing the impact our life has on the environment.

We recycle, repair, up-cycle and resell stoves. By buying one of our recycled Stoves you are ensuring the hazardous contaminants such as the copper, cadmium, hexavalent chromium, flame retardants, lead and plastics are kept from landfills or other locations where they could impact the local environment.

Reuse ensures that no further carbon is emitted into our atmosphere to manufacture and transport whiteware which can lengthen the life of our landfills. There are few items in a stove that cannot be repaired or replaced. Reuse, refurbishment and right-to-repair is strong in our business model.

Recycling creates a closed loop in the economy, gives these stoves a new lease on life and promotes local employment. All this and you'll have a company that backs up the sale with a carefully inspected and repaired stove so you'll have our 90 day warranty.

# USER MANUAL

600mm Upright Cooker

WLE620WA, WLE622WA,  
WLE624WA, WLE625WA,  
WLE626WA, WLE644WA,  
WLE645WA, WLE646WA



**Westinghouse**

## CONGRATULATIONS

Congratulations and thank you for choosing our cooker. We are sure you will find your new appliance a pleasure to use. Before you use the appliance, we recommend that you read through the entire user manual, which provides the description of the appliance and its functions.

To avoid the risks that are always present when you use an electrical appliance, it is important that the appliance is installed correctly and that you read the safety instructions carefully to avoid misuse and hazards.

We recommend that you keep this instruction booklet for future reference and pass it on to any future owners.

After unpacking the appliance, please check that it is not damaged. If in doubt, do not use the appliance but contact your local customer care centre.

### Conditions of use

This appliance is intended to be used in household and similar applications such as:

- Staff kitchen areas in shops, offices and other working environments
- Farm houses
- By clients in hotels, motels and other residential type environments
- Bed and breakfast type environments
- Catering and similar non-retail applications

**Please ensure you read the instruction manual fully before you call for service, or a full service fee could be applicable.**

Record model and serial number here:

Model number: .....

Serial number: .....

## CONTENTS

|  |    |
|--|----|
| Important safety instructions .....      | 3  |
| Installation .....                       | 4  |
| Controls.....                            | 8  |
| Understanding the cooker .....           | 12 |
| Using the hotplates .....                | 14 |
| Understanding the functions.....         | 15 |
| Cooking guide for ovens .....            | 17 |
| Get to know your oven .....              | 19 |
| Handling baking & grilling problems..... | 20 |
| Clocks.....                              | 21 |
| Cleaning and caring for the cooker ..... | 23 |
| Cleaning and caring for the oven.....    | 24 |
| Installation.....                        | 24 |
| Solving problems.....                    | 27 |
| Warranty .....                           | 30 |

The symbols you will see in this booklet have these meanings:



### WARNING

This symbol indicates information concerning your personal safety.



### CAUTION

This symbol indicates information on how to avoid damaging the appliance.



### IMPORTANT

This symbol indicates tips and information about use of the appliance.



### ENVIRONMENT

This symbol indicates tips and information about economical and ecological use of the appliance.



### IMPORTANT

Check for any damage or marks

If you find the appliance is damaged or marked, you must report it within 7 days if you wish to claim for damage/marks under the manufacturer's warranty. This does not affect your statutory rights.



### ENVIRONMENT

Information on disposal for users

- Most of the packing materials are recyclable. Please dispose of those materials by contacting your local authorities and ask for the correct method of disposal.

## IMPORTANT SAFETY INSTRUCTIONS

Before you use the appliance, we recommend that you read through the relevant sections of this manual, which provides the description of your appliance and its functions. To avoid the risks that are always present when you use an appliance, it is important that the appliance is installed correctly and that you read the safety instructions carefully to avoid misuse and hazards.

This appliance complies with the requirements of Australian/New Zealand Standard AS/NZS 60335.2.6



### WARNING

- Cooker is designed to be placed on the floor. It should not be placed on a base.
- This appliance is not suitable for use by young children or infirm persons, without supervision.
- Young children should be supervised to ensure they do not play with this appliance.
- During use, this appliance becomes hot. Care should be taken to avoid touching hot surfaces.
- This appliance must not be used as a space heater.
- Keep vents clear of obstructions.
- In order to avoid a fire, the appliance must be kept clean and vents kept unobstructed.
- Do not spray aerosols in the vicinity of the appliance when it is in operation.
- Do not store flammable materials in or under the appliance, e.g. aerosols.
- Accessible parts will become hot when in use. To avoid burns and scalds children should be kept away.
- If the supply cord is damaged it must be replaced by a suitably qualified person in order to avoid a hazard.
- Oven gloves should be worn when accessing hot internal parts.
- The warming drawer must not be used to warm, heat or preheat food due to health regulations.

### Grill

- Always turn the grill off immediately after use as fat left there may catch fire.
- Do not cover the insert with foil, as fat left there may catch fire.
- Always keep the grill dish clean as any fat left may catch fire.
- Do not leave the grill on unattended.
- To avoid a fire, ensure that grill trays and fittings are always inserted into the appliance in accordance with the instructions.
- Do not place thick portions of food under the grill. Foods may curl, catch and ignite.
- Do not store flammable materials in the grill.

### Oven

- During use the appliance becomes hot. Care should be taken to avoid touching hot surfaces inside the oven.
- Switch the appliance off before removing the oven light glass for globe replacement.
- To avoid an accident, ensure that oven shelves and fittings are always inserted into the appliance in accordance with the instructions.
- Do not use the oven door as a shelf.
- Do not push down on the open oven door.

### Hotplates (Generally)

- Do not allow pots to boil dry, as damage to both pan and hotplate may result.
- Do not operate the hotplates for an extended period of time without a utensil on the hotplate.
- Do not allow large cookware to overhang the hob onto the adjacent benchtop. This will cause scorching to the benchtop surface.
- Do not allow cooking utensils to intrude into the area which is close to the controls.

### Ceramic Glass

- If the ceramic glass is accidentally cracked switch off the appliance to avoid the possibility of electric shock.
- Do not place heat resistant mats, wire mats or aluminium foil under pots or pans.
- Do not cook food directly on the ceramic glass surface.
- Do not use round bottom woks or similar utensils which could lead to over heating of hotplates and possible damage to the cooking surface.
- Do not use the ceramic cooktop as extra bench space or as a cutting board.

### Installation, Cleaning and Servicing

- An authorised person must install this appliance. (Certificate of Compliance to be retained).
- Before using the appliance, ensure that all packing materials are removed from the appliance.
- In order to avoid any potential hazard, the enclosed installation instructions must be followed.
- Ensure that all specified vents, openings and airspaces are not blocked.
- In order to avoid accidental tipping of the appliance (for example, by a child climbing onto the open oven door), the anti-tilt bracket must be installed.
- Where the appliance is built into a cabinet, the cabinet material must be capable of withstanding 85°C.
- Only authorised personnel should carry out servicing. (Certificate of Compliance to be retained).
- Always ensure the appliance is switched off before cleaning or replacing parts.
- This appliance contains aluminium fittings. Do not use caustic based cleaners.
- Do not use steam cleaners, as this may cause moisture build up.
- Always clean the appliance immediately after any food spillage.
- Do not use harsh abrasive cleaners or sharp metal scrapers to clean the oven door glass since they can scratch the surface, which may result in shattering of the glass.
- To maintain safe operation, it is recommended that the product be inspected every five years by an authorised service person.
- This appliance must be earthed.



### CAUTION

- Separate grill model - grill with door open.
- Grill in oven model - grill with door closed.

## INSTALLATION

### WARNING

This appliance must be installed by an authorised person in compliance with local municipal building codes and any other relevant statutory regulation.

Wiring connections must be made in accordance with: New Zealand & Australian requirements, including AS/NZS 3000 WIRING RULES.

Refer to data plate for rating information. The data plate is positioned on the bottom of the oven front, viewable with the oven door open.

- Electrical connection is 230–240 volts AC 50 Hz.
- To gain access to the mains connection terminals, remove the rear cover by unscrewing the two assembly screws.
- The cooker requires a means of all pole disconnection incorporated into the fixed wiring. This MUST have a disconnection gap of 3mm.
- The cooker MUST be earthed. Any damage caused by failure to earth will not be covered by warranty.
- This range must be connected with cable of 75°C rating minimum.
- This product has passed the insulation resistance test after manufacture. If the resistance reading is low at installation, it is probably caused by moisture from the atmosphere being absorbed by the elements after the range has been produced. (Pass at 0.01MΩ AS/NZS 3000 Wiring Rules Clause 8.3.6.2).

*NOTE: Where connection is made to a multi-phase 220/240V supply, the bridge piece must be removed from between the active connections on the main terminal block.*

### Fuse (for New Zealand only)

Should the fuse need servicing it is accessible through the fuse opening located in the back cover. The Cooking range must be connected to the supply by a supply cord fitted with the appropriately rated plug with the socket-outlet fitted to the final sub-circuit in the fixed wiring that is intended to supply this cooking range. See table below.

### Supply cord specifications

| MODEL    | CURRENT RATING (AMPS) | WIRE SECTION (MM <sup>2</sup> ) | MINIMUM TEMP RATING (°C) |
|----------|-----------------------|---------------------------------|--------------------------|
| WLE620WA | 25                    | 2.5                             | 75                       |
| WLE622WA | 32                    | 4.0                             | 75                       |
| WLE624WA | 32                    | 4.0                             | 75                       |
| WLE625WA | 32                    | 4.0                             | 75                       |
| WLE626WA | 32                    | 4.0                             | 75                       |
| WLE644WA | 32                    | 4.0                             | 75                       |
| WLE645WA | 32                    | 4.0                             | 75                       |
| WLE646WA | 32                    | 4.0                             | 75                       |

### Hard wiring detail

1. Remove terminal cover plate from rear panel of appliance.
2. Fit wires through hole in cover plate and make connections to terminals.
3. Engage wires into plastic clip. Secure plastic clip with two long silver screws (supplied in separate bag).
4. Replace cover plate onto rear panel.

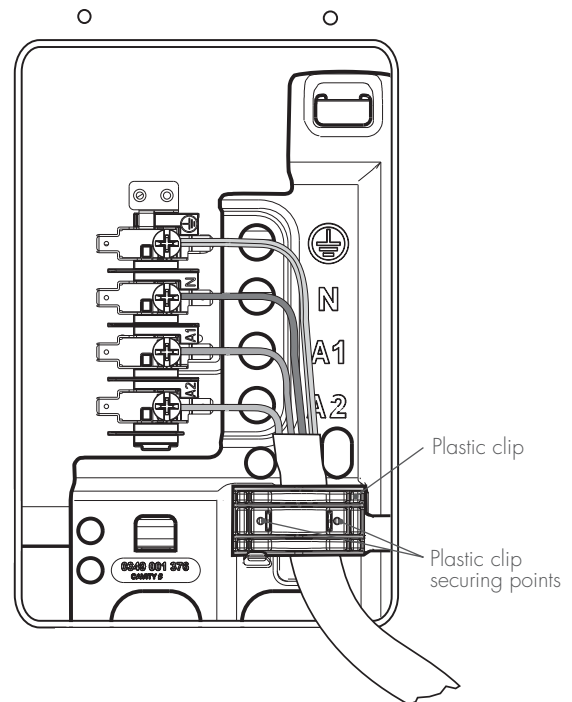

### Rated Power Input

| MODEL  | TOTAL kW | A1 kW | A2 kW |
|--------|----------|-------|-------|
| WLE620 | 9.7      | 3.1   | 6.6   |
| WLE622 | 11.7     | 5.1   | 6.6   |
| WLE624 | 12.1     | 5.5   | 6.6   |
| WLE625 | 10.7     | 4.1   | 6.6   |
| WLE626 | 12.1     | 5.5   | 6.6   |
| WLE644 | 11.4     | 5.0   | 6.4   |
| WLE645 | 10.5     | 4.1   | 6.4   |
| WLE646 | 11.8     | 5.4   | 6.4   |

## INSTALLATION



CAUTION



### Installation dimensions



WARNING

### Installers responsibility

In ALL cases the anti-tilt bracket **MUST** be securely anchored to the floor with suitable fasteners, and the stability bolt fixed.

The anti-tilt bracket is a mandatory safety restraint. In order to prevent accidental tipping of the appliance; for example by a child climbing onto the open door, the anti-tilt bracket supplied with the cooker **MUST** be installed. **ALWAYS** ensure that the cooker is located so that the anti-tilt bracket is engaged into the cooker.

### Step 1: Positioning

Choose the most practical bracket mounting option for your cooker. The anti-tilt bracket can be floor mounted or floor and skirting mounted depending on the location of the range plug/socket/connection.

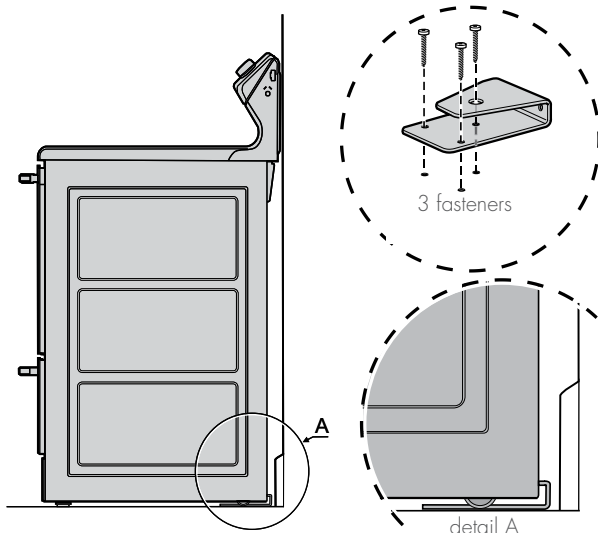

### Step 2: Fixing anti-tilt bracket

Position the anti-tilt bracket so that it will fully engage into the slot at the rear of the cooker. The bracket is mounted centrally at the rear of the cooker. Anchor the bracket into position using appropriate fasteners.

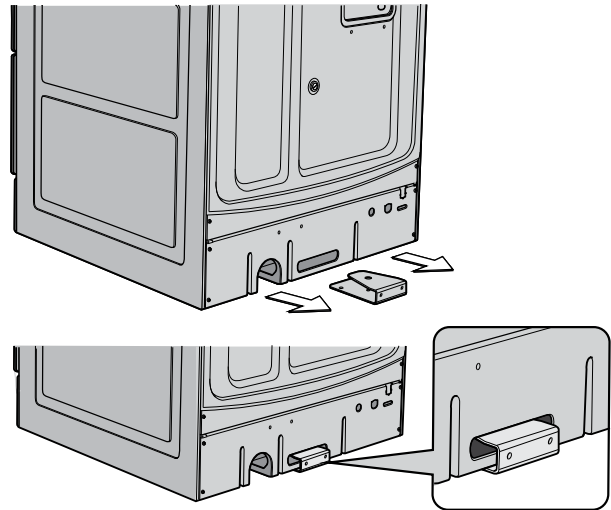

The appliance must not be installed in a corner. It must be installed at least 100mm from the side wall.

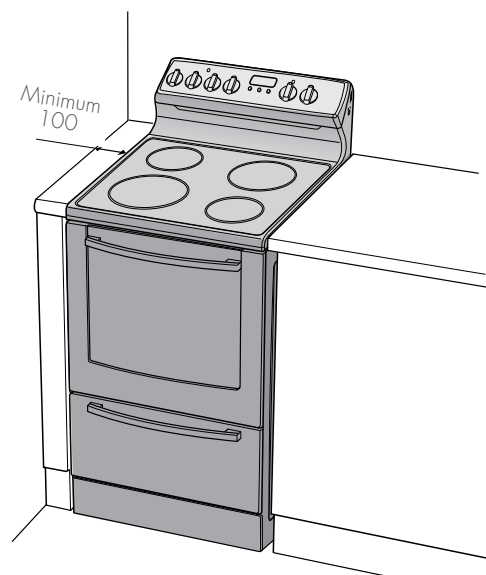

## INSTALLATION



### WARNING

#### Step 3: Stability bolt

1. Remove oven door – to be done by qualified personnel only. (Refer to procedure).
2. Remove screws from kick panel. To remove kick panel lift kick panel upwards to release the two Location Tabs from the holes in the bottom of the panel.
3. Position the cooker into the anti-tilt bracket.
4. Remove the tape from the stability bolt.
5. Rotate the stability bolt 180° clockwise until it is pointing to the left like the picture below.
6. The stability bolt should now be able to drop to the floor.
7. Mark the position for the stability bolt on the floor.
8. Pull the cooker out and drill the bolt hole, using a 6.5mm masonry or wood drill. Minimum 30mm deep for concrete.
9. Reposition the cooker back into place, then fit the stability bolt into the drilled hole.

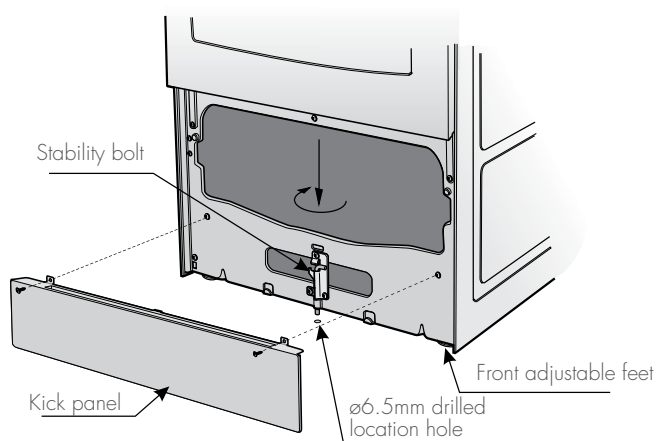

### IMPORTANT

#### Setting the time

If you have purchased a model fitted with an electronic or programmable clock, you **MUST** set the time of day before you can operate your appliance.



## INSTALLATION



**WARNING**

### Fitting oven shelves

1. Ensure shelf orientation is correct (refer to diagram below).
2. Slide oven shelves onto oven supports (side runners) at an angle until raised back of shelf is past the stop on oven supports (side runners).
3. Lower front of shelf and push in until stop is reached.
4. To remove oven shelves, withdraw to the stop and raise the front of shelf to clear the stop.

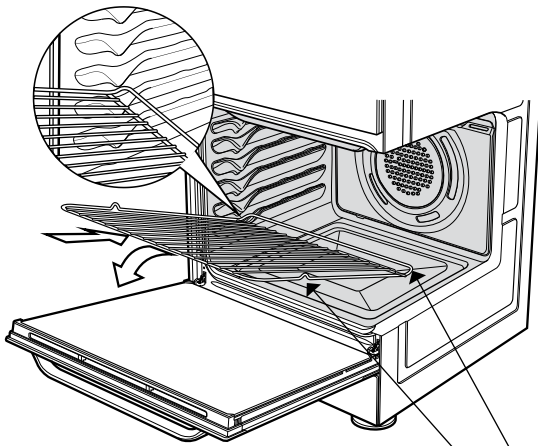

Note the orientation of the side and rear features

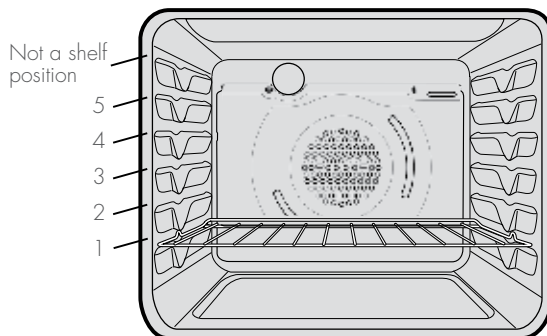

5 shelf positions

*NOTE: The top ledge is not a shelf position. There are no stops for shelf withdrawal.*

### Assemble grill tray handle

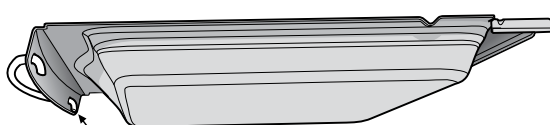

Assemble grill tray handle as shown

### Fitting the grill dish supports

- Insert the rear hook into the rear hole.
- Align the front peg to the front hole and push in firmly.

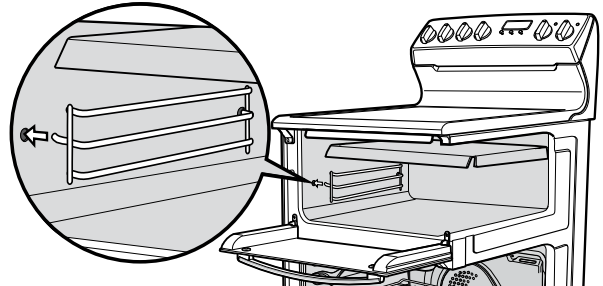

### Fitting the grill dish

#### Separate grill

Ensure rear of the dish is engaged with the side support before sliding backwards. To remove, simply pull forwards and upwards.

Engagement of rear dish

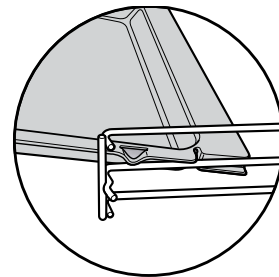

#### Grill in oven

(Refer to Fitting Oven Shelves)

The grill dish with wire insert can be used in any of the two upper height positions (shelf positions 4 and 5) between the runners.

*NOTE: You must remove the grill dish when baking in the oven.*

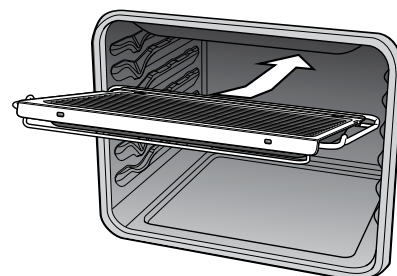

Grill dish insertion

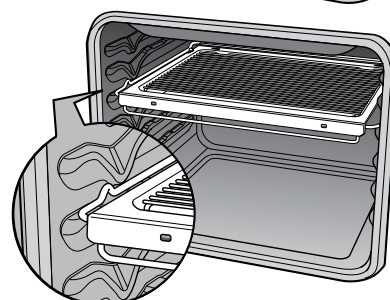



Grill dish final position

## CONTROLS



### WLE620WA – Mercury



1. **Hotplate Control Knobs**
  - Adjusts temperature of hotplate. Can be rotated in either direction.
2. **Hotplate Indicator Lamp**
  - Comes on when you turn a hotplate on.
3. **Temperature Control Knob**
  - Sets temperature for baking.
4. **Oven Indicator Lamp**
  - Comes on when you operate the oven temperature control knob. Cycles on and off automatically when you are cooking/baking.
5. **Function Switch**
  - Sets oven functions.
    -  Bake - with light
    -  Grill - with light
    -  Light - light only

### WLE622WA – Columbo



1. **Hotplate Control Knobs**
  - Adjusts temperature of hotplate. Can be rotated in either direction.
2. **Hotplate Indicator Lamp**
  - Comes on when you turn a hotplate on.
3. **Temperature Control Knob**
  - Sets temperature for baking.
4. **Oven Indicator Lamp**
  - Comes on when you operate the oven temperature control knob. Cycles on and off automatically when you are cooking/baking.
5. **Function Switch**
  - Sets oven functions.
    -  Bake - with light
    -  Grill - with light
    -  Light - light only
6. **Timer**
  - Sets reminder time.
7. **General Purpose Outlet Switch**

## CONTROLS

### WLE624WA – Neptune

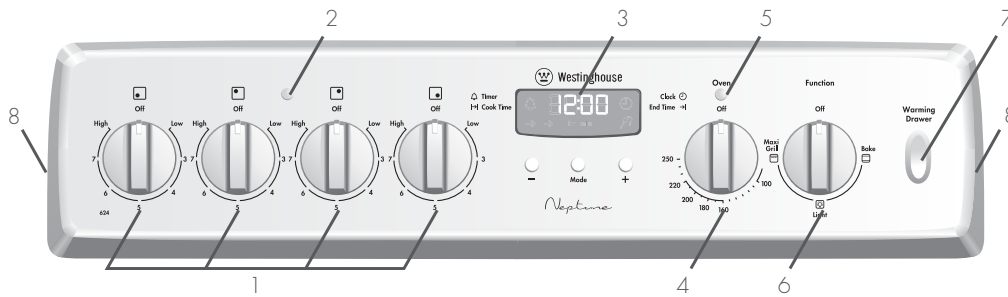

1. **Hotplate Control Knobs**
  - Adjusts temperature of hotplate. Can be rotated in either direction.
2. **Hotplate Indicator Lamp**
  - Comes on when you turn a hotplate on.
3. **Programmable Clock**
  - Sets baking/grilling reminder times.
  - Sets automatic cooking duration and stop time.  
*NOTE: Clock time must be set before oven can operate.*
4. **Temperature Control Knob**
  - Sets temperature for baking.
5. **Oven Indicator Lamp**
  - Comes on when you operate the oven temperature control knob. Cycles on and off automatically when you are cooking/baking.
6. **Function Switch**
  - Sets oven functions.
    - Bake - with light
    - Grill - with light
    - Light - light only
7. **Warming Drawer Switch**
  - Turns warming drawer on/off.
8. **General Purpose Outlet Switch**

### WLE625WA





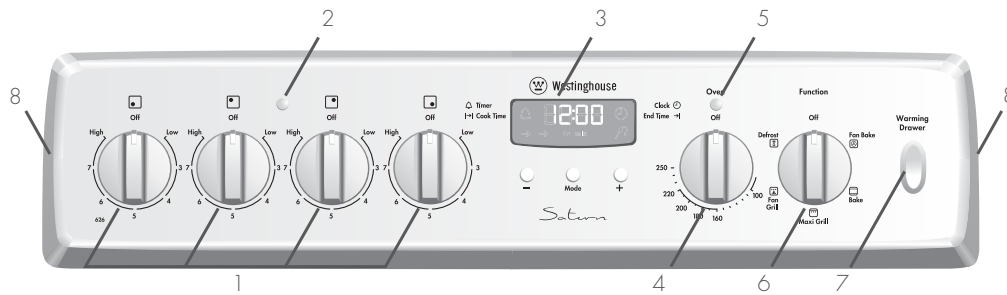

1. **Hotplate Control Knobs**
  - Adjusts temperature of hotplate. Can be rotated in either direction.
2. **Hotplate Indicator Lamp**
  - Comes on when you turn a hotplate on.
3. **Temperature Control Knob**
  - Sets temperature for baking.
4. **Oven Indicator Lamp**
  - Comes on when you operate the oven temperature control knob. Cycles on and off automatically when you are cooking/baking.
5. **Grill Temperature Control Knob**
  - Sets grilling temperature for separate grill. Can be rotated in either direction.
6. **Grill Indicator Lamp**
  - Comes on when you are grilling.
7. **Timer**
  - Sets reminder time.

## CONTROLS



### WLE626WA – Saturn

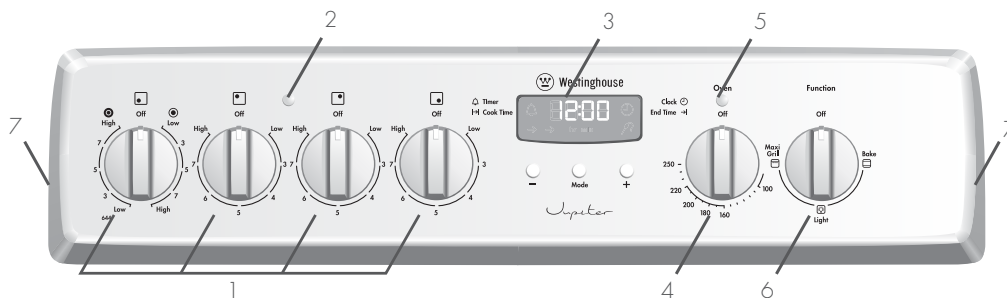

1. **Hotplate Control Knobs**
  - Adjusts temperature of hotplate.  
Can be rotated in either direction.
2. **Hotplate Indicator Lamp**
  - Comes on when you turn a hotplate on.
3. **Programmable Clock**
  - Sets baking/grilling reminder times.
  - Sets automatic cooking duration and stop time.
  - NOTE: Clock time must be set before oven can operate.*
4. **Temperature Control Knob**
  - Sets temperature for baking.
5. **Oven Indicator Lamp**
  - Comes on when you operate the oven temperature control knob. Cycles on and off automatically when you are cooking/baking
6. **Function Switch**
  - Sets oven functions (all functions include oven light)
  -  Fan Bake
  -  Bake
  -  Maxi Grill
  -  Fan Grill
  -  Defrost
7. **Warming Drawer Switch**
  - Turns warming drawer on/off.
8. **General Purpose Outlet Switch**

### WLE644WA – Jupiter



1. **Hotplate Control Knobs**
  - Adjusts temperature of hotplate.  
Can be rotated in either direction.
2. **Hotplate Indicator Lamp**
  - Comes on when you turn a hotplate on.
3. **Programmable Clock**
  - Sets baking/grilling reminder times.
  - Sets automatic cooking duration and stop time.
  - NOTE: Clock time must be set before oven can operate.*
4. **Temperature Control Knob**
  - Sets temperature for baking.
5. **Oven Indicator Lamp**
  - Comes on when you operate the oven temperature control knob. Cycles on and off automatically when you are cooking/baking.
6. **Function Switch**
  - Sets oven functions.
  -  Bake - with light
  -  Grill - with light
  -  Light - light only
7. **General Purpose Outlet Switch**

## CONTROLS

WLE645WA



1. **Hotplate Control Knobs**
  - Adjusts temperature of hotplate. Can be rotated in either direction.
2. **Hotplate Indicator Lamp**
  - Comes on when you turn a hotplate on.
3. **Temperature Control Knob**
  - Sets temperature for baking.
4. **Oven Indicator Lamp**
  - Comes on when you operate the oven temperature control knob. Cycles on and off automatically when you are cooking/baking.
5. **Grill Temperature Control Knob**
  - Sets grilling temperature for separate grill. Can be rotated in either direction.
6. **Grill Indicator Lamp**
  - Comes on when you are grilling.
7. **Timer**
  - Sets reminder time.

WLE646WA – Apollo

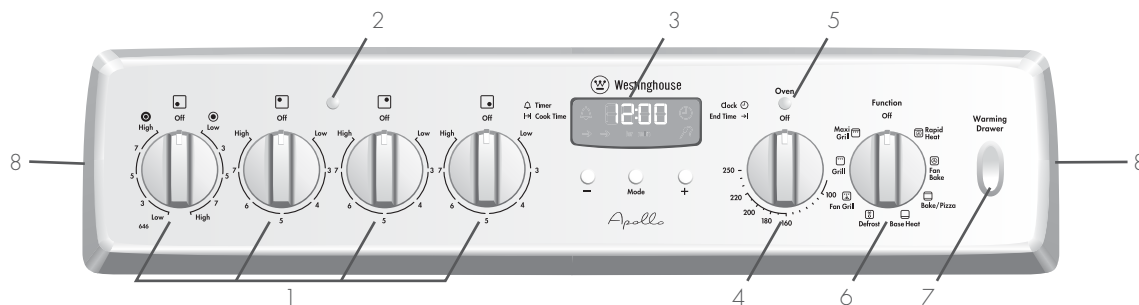

1. **Hotplate Control Knobs**
  - Adjusts temperature of hotplate. Can be rotated in either direction.
2. **Hotplate Indicator Lamp**
  - Comes on when you turn a hotplate on.
3. **Programmable Clock**
  - Sets baking/grilling reminder times.
  - Sets automatic cooking duration and stop time

*NOTE: Clock time must be set before oven can operate.*
4. **Temperature Control Knob**
  - Sets temperature for baking.
5. **Oven Indicator Lamp**
  - Comes on when you operate the oven temperature control knob. Cycles on and off automatically when you are cooking/baking.
6. **Function Switch**
  - Sets oven functions (all functions include oven light)
  - Rapid Heat
  - Fan Bake
  - Bake/Pizza
  - Base Heat
  - Defrost
  - Fan Grill
  - Grill
  - Maxi Grill
7. **Warming Drawer Switch**
  - Turns warming drawer on/off.
8. **General Purpose Outlet Switch**

# UNDERSTANDING THE COOKER

Separate grill models

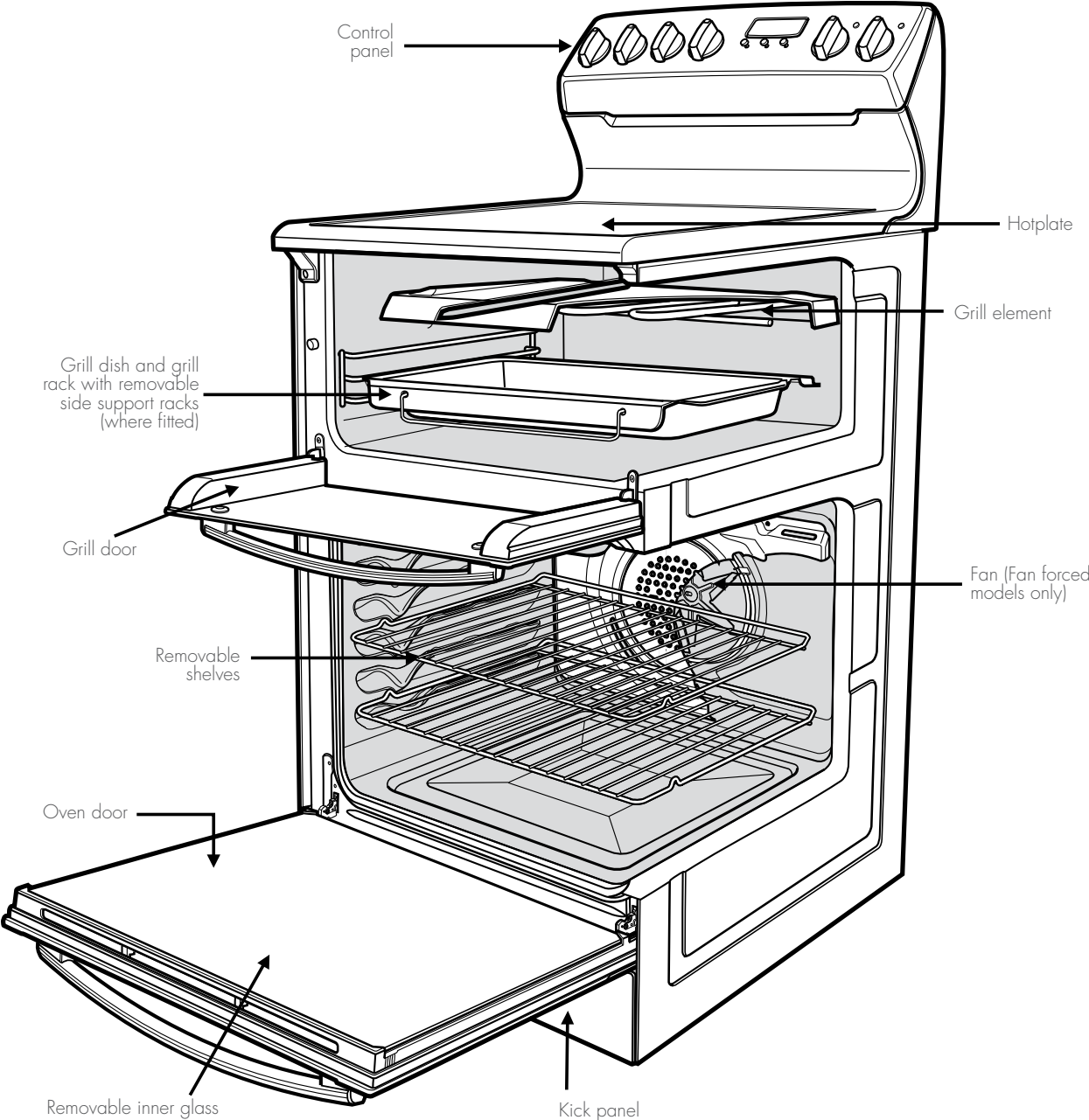

# UNDERSTANDING THE COOKER

## Grill in oven models

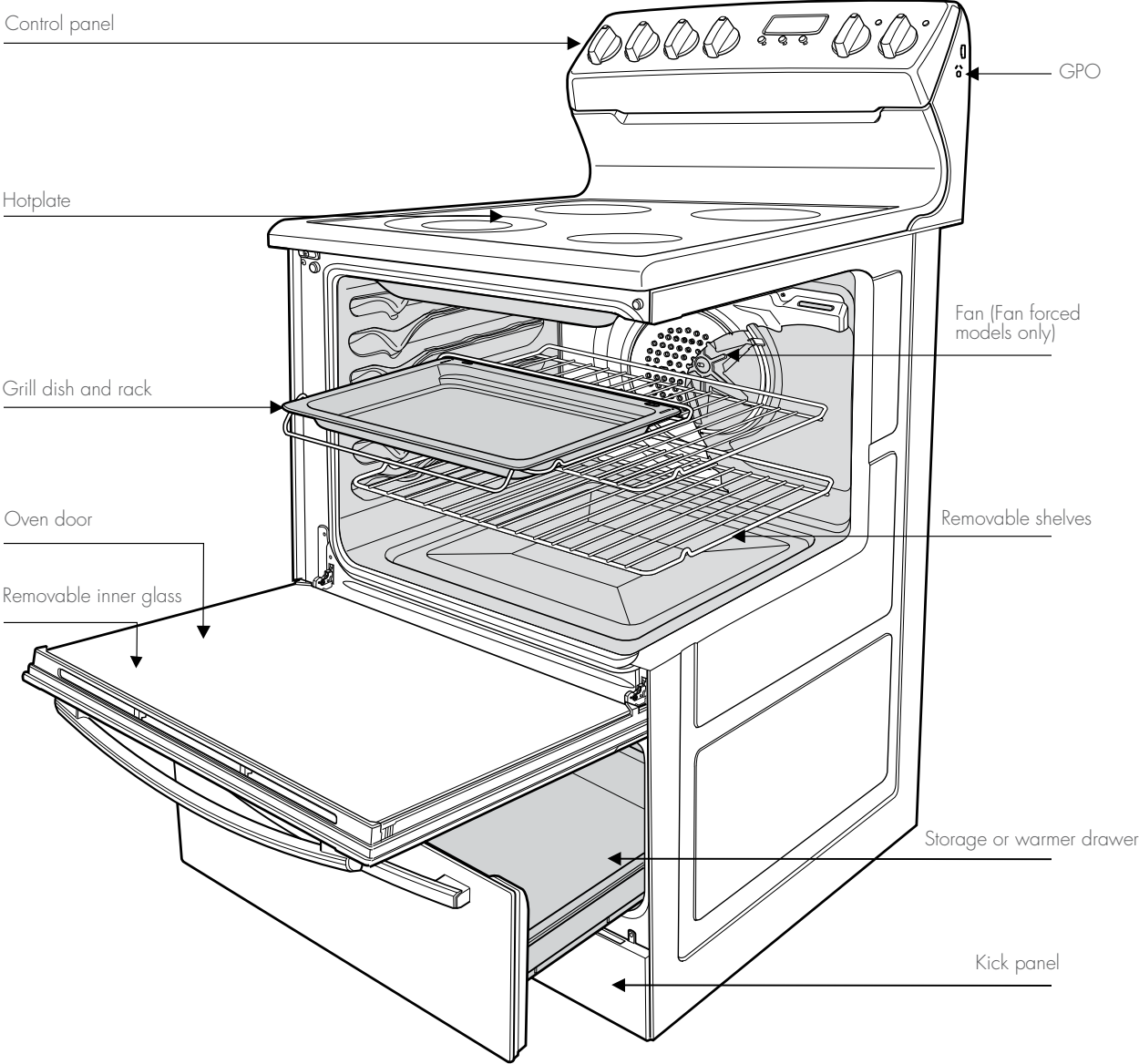



## USING THE HOTPLATES

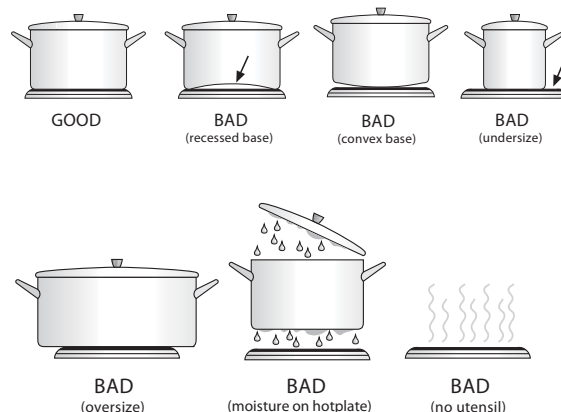
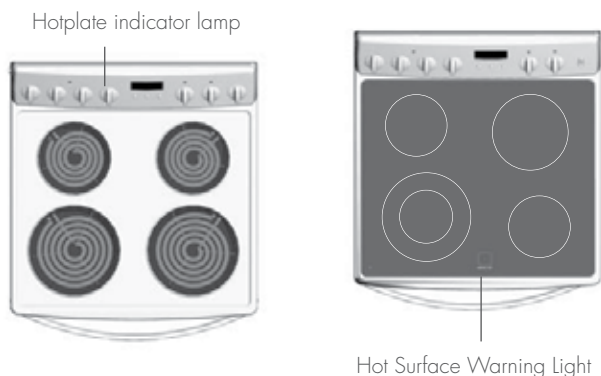

### Radiant Hotplates

The high-speed radiant coil hotplates heat rapidly from a cold start to give you economic use of power. Radiant hotplate models have a bowl under each element for collecting spillage.

The radiant elements are removable to aid in cleaning the hob and spillage bowls. The spillage bowl can be removed by first removing the element and then removing the spillage bowl.

### Ceramic Hotplates

The ceramic cooktop is made from ceramic glass, a tough durable material that withstands heating and cooling without breaking. However it must be remembered that it is glass, it may break. Treat it accordingly!

Should you have any questions about the glass in your appliance, please contact the Customer Care Centre by calling:

1300 363 640 (Australia)

0800 436 245 (New Zealand)



### WARNING

If the ceramic glass is cracked, switch off the appliance to avoid the possibility of electric shock.

### Utensils

- Use pans with flat bottoms. Uneven or thin bottoms will waste energy and result in slow cooking.
- Use pans slightly larger than the hotplates. Small pans will waste energy.
- Do not use oversize pans. More than 50mm overhang can overheat cooktop components and can cause fine cracks in the enamel hob which will trap dirt.
- Use only dry utensils. Do not place wet or steamy parts (eg. lids) on the hotplates.
- Do not use pots and pans that are unsteady and likely to rock or over balance.
- Do not operate the cooktop for an extended time without a utensil on the hotplate.

### Cooking Do's and Don'ts

- Do use the stored heat in the hotplate by turning the control to "0" before the final few minutes of cooking.
- Do not place heat resistant mats, wire mats or aluminium foil under pots and pans.
- Do not allow pots and pans to boil dry, as damage to both pan and hotplate may result.
- Do not use round bottom woks or similar utensils which could lead to overheating of the hotplates and possible damage to the cooking surface.
- Do not use the cooktop as extra bench space or as a cutting board.
- Do not allow children on or near the cooktop at any time.



## UNDERSTANDING THE FUNCTIONS



### CAUTION

Do not line the bottom of the oven with foil or place anything on bottom surface of oven liner as trapped heat will crack or craze oven liner.

ALWAYS remove unnecessary trays or dishes from oven when baking or roasting.

### Preheating Oven

1. For best results when baking preheat your appliance for 30 minutes.
2. When the oven indicator light goes out, put your food in the oven and close the door. Once your food is placed in the oven adjust the temperature back to the required setting.

### Base Heat

Heat comes from the element below the food. The element is controlled by the thermostat and will turn on and off to maintain the set temperature. You can use the "Base Heat" function for single trays of biscuits, cakes, slices, pies, pizzas and quiches, anything that requires more cooking on the bottom. Cook in the lower half of your oven when you are using only one shelf.

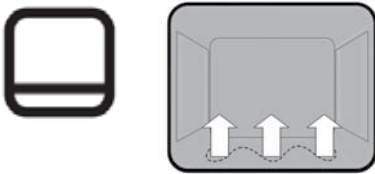

### Bake

Heat comes from two elements, one above and one below the food. The bottom element is a clean heat element and is below the floor of the oven. Both elements are controlled by the thermostat and will turn on and off to maintain the set temperature.

You can use the "Bake" function for single trays of biscuits, scones, muffins, cakes, slices, casseroles, baked puddings, roasts, delicate egg dishes, anything that requires delicate baking.

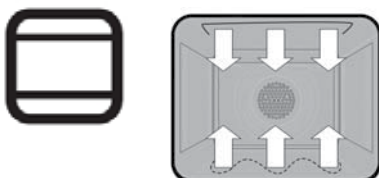

### Fan Bake

Heat comes from the element surrounding the fan. This fan circulates the hot air around the oven cavity so that you can put your food in different places in the oven and still cook them at the same time.

You can use the function for multi shelf cooking, reheating cooked foods, pastries and complete oven meals. Fan Bake may cook at a lower temperature and be faster than the "bake" or "base heat" option. Please note that some variation in browning is normal.

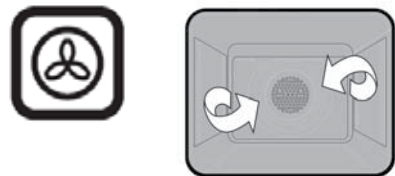

### Rapid Heat

"Rapid Heat" allows you to preheat your oven quickly before cooking. With "Rapid Heat" the fan, fan element and the top bake elements turn on to heat the oven to the required temperature. "Rapid Heat" can also be used to quickly cook convenience meals and provide browning.



### Defrosting

The "Defrost" function uses ambient temperature air that is circulated by the fan. You can defrost (thaw) your food before you cook it. You can also use "Defrost" to raise your yeast dough and to dry fruit, vegetables and herbs.



## UNDERSTANDING THE FUNCTIONS



### WARNING

Always turn your grill off immediately after use, as fat left there may catch fire.

Do not cover the grill rack with foil. The cooker is supplied with a grill tray that fits into the meat dish. When grilling, use one of the top two side runner positions. (Position will depend on the thickness of food being grilled).



### WARNING

Accessible parts may become hot when the grill is in use. Children should be kept away.

### Fan Grilling

"Fan grill" offers you the benefits of both "Bake" and traditional "Grill" functions. The grill element turns on and off to maintain the set temperature while the fan circulates the heated air. The oven door remains closed for fan grill. In this mode it is recommended that the thermostat is set to 180°C.

You can use "Fan grill" for large cuts of meat, which gives you a result that is similar to "Rotisserie" cooked meat. The cooker is supplied with a grill tray that fits into the meat dish. When fan grilling, position tray in lower section of the oven. (Position will depend on thickness of food being grilled).

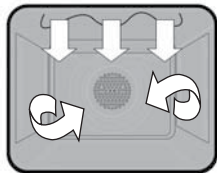

### Grilling (In Oven)

The "Grill" directs radiant heat from the powerful upper element onto the food. You can use the "Grill" function for tender cuts of meat, steak, chops, sausages, fish, cheese toasties and other quick cooking foods. Preheat your grill for 3 minutes to get the best results. This will help seal in the natural juices of steak, chops etc. for a better flavour. Grill with the door open to the first stop position.

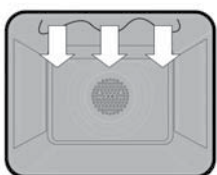

### Grilling (Separate)

The "Grill" works by directing radiant heat which comes from the powerful upper element onto the food. The grill function is suitable for tender cuts of meat, steak, chops, sausages, fish, cheese toasties and other quick cooking foods.

Best results are obtained after 3 minutes preheat. This will help seal in the natural juices of steak, chops etc. for a better flavour.

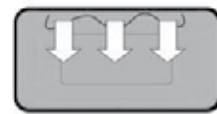

### Grilling - Maxi Grill (In Oven)

The "Maxi Grill" directs radiant heat from the powerful upper grill element and the upper bake element onto the food.

You can use the "Maxi Grill" function for tender cuts of meat, steak, chops, sausages, fish, cheese toasties and other quick cooking foods.

Preheat your grill for 3 minutes to get the best results. This will help seal in the natural juices of steak, chops etc. for a better flavour. Grill with the door open to the first stop position.

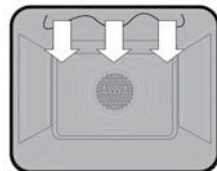

## COOKING GUIDE FOR OVENS



| FOOD                       | BAKE | FAN BAKE | BASE HEAT | GRILL | FAN GRILL | MAXI GRILL | RAPID HEAT |
|----------------------------|------|----------|-----------|-------|-----------|------------|------------|
| <b>Baked Products</b>      |      |          |           |       |           |            |            |
| Single trays               | R    | R        | A         |       |           |            | A          |
| 3 trays                    |      | R        |           |       |           |            | A          |
| 2 trays                    |      |          | R         |       |           |            |            |
| Scones/small cakes         | R    | R        | R         |       |           |            | R          |
| Muffins                    | R    | R        |           |       |           |            | R          |
| Slices                     | R    | R        | A         |       |           |            | R          |
| Cakes                      | R    | A        | A         |       |           |            |            |
| Fruit Cakes                | R    | R        | A         |       |           |            |            |
| <b>Egg Recipes</b>         |      |          |           |       |           |            |            |
| Baked Custards             |      | R        | R         |       |           |            |            |
| Pavlova                    |      | A        | A         |       |           |            |            |
| Meringues                  |      | A        | R         |       |           |            |            |
| <b>Pies &amp; Pastry</b>   | R    | A        | A         |       |           |            |            |
| <b>Fish</b>                | R    | R        |           |       |           |            |            |
| <b>Meats</b>               |      |          |           |       |           |            |            |
| Beef Roast                 | A    | A        |           |       |           |            | R          |
| Beef Steaks                |      |          |           | A     | R         | R          |            |
| Beef Patties               |      |          |           | A     | R         | R          |            |
| Lamb Roast                 | A    | A        |           |       | R         |            | R          |
| Lamb Chops                 |      |          |           | A     |           | R          |            |
| Pork Roast                 | A    | A        |           | A     |           |            | R          |
| Pork Chops                 |      |          |           |       | R         | R          |            |
| Pork Fillets               | R    | R        |           | A     |           | R          | R          |
| <b>Sausages</b>            |      |          |           | A     | A         | R          |            |
| <b>Poultry</b>             |      |          |           |       |           |            |            |
| Chicken Whole              | A    | A        |           | A     | R         |            | R          |
| Chicken Pieces             | R    | R        |           | A     | A         | A          | R          |
| Turkey                     | A    | A        |           | A     |           | A          | R          |
| <b>Casseroles</b>          | A    | R        | R         |       | A         |            | R          |
| <b>Complete Oven Meals</b> | R    | A        | R         | R     | A         | R          | R          |

R Recommended Method

A Alternative Method

## UNDERSTANDING THE FUNCTIONS

### General Purpose Socket Outlets (If fitted)

The socket outlet may be used for general applications. A 15A fuse mounted in the rear of the appliance protects the socket outlet.

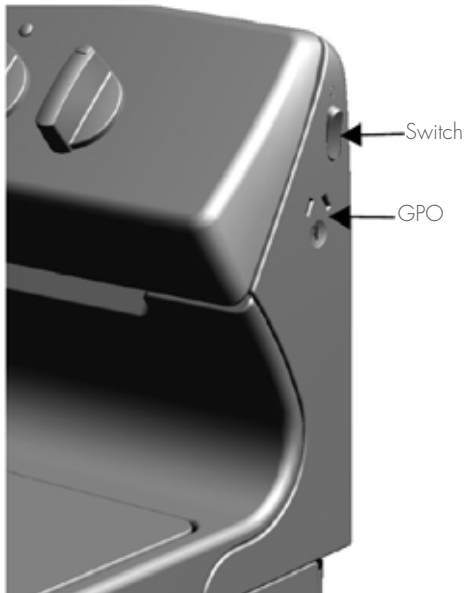

### Warming Drawer

The warming drawer may be used to warm crockery prior to use. Recommend warming times 30 minutes, refer to general warnings.



#### WARNING

DO NOT use the drawer for heating food.  
DO NOT place flammable material in the drawer.  
DO NOT store aerosols or cleaning products in the drawer.  
DO NOT store plastic items in the drawer.  
DO NOT place more than the maximum weight of 10kg in the drawer.

## GET TO KNOW YOUR OVEN

### Get to know your new oven with this 'Simple Test Cake'

Although we strive for a perfect performing oven, it's possible that there will be some variation in colour when baking. Therefore, we suggest this simple, easy and delicious to make Simple Test Cake, it can help you understand your new oven.

All ovens do sometimes have hot or cold spots, therefore it is important to judge with your eye as you may require to rotate during baking.

### 'Simple Test Cake'

125g butter, softened to room temperature  
1 cup caster sugar  
1 teaspoon pure vanilla essence  
4 large eggs  
2 cups self-raising flour  
Pinch of salt  
4 tablespoons (80mL) full-cream milk

### Method:

1. Butter base and sides of two, 20cm straight-sided round or square cake pans. Then line the base with grease proof or baking paper.
2. Preheat oven to moderate '180°C' (170°C fan forced) and ensure oven shelf is in the centre position of oven.
3. Cream softened butter and sugar until light in colour.
4. Add vanilla essence.
5. Then eggs one at a time, beating well after each addition.
6. Sift flour and salt into the mixture and beat until well combined.
7. Add milk and beat or stir to combine.
8. Spoon mixture equally between prepared cake pans.
9. Bake in preheated oven, middle shelf for about 25 to 35 minutes or until when tested with a fine cake skewer it comes out clean or the edges of the cakes have come away slightly from the sides of the cake pans.
10. Remove from oven to wire cake rack and rest for 5 minutes before removing from cake pans. Cool completely.

To serve: Sandwich together with your favourite jam or conserve, and dust top with pure icing sugar.

NOTE: If desired, substitute butter for either margarine or olive oil spread.

Recipe is based on the Australian standard metric 250mL cup and 20mL tablespoon sets.

## HANDLING BAKING & GRILLING PROBLEMS

| PROBLEM   | CAUSES  | REMEDIES  |
|---|---|---|
| Uneven cooking  | • Incorrect shelf position.                           | - Select shelf that puts food in the centre of the oven.                    |
|   | • Oven tray too large.                                | - Experiment with other trays or dishes.                                    |
|   | • Trays not centralised.                              | - Centre trays.   |
|   | • Food has not been rotated.                          | - Rotate food during cooking.   |
| Baked products too brown on top                         | • Oven not preheated.                                 | - Preheat until the oven indicator lamp goes off.                           |
|   | • Aluminium foil in oven.                             | - Remove foil.  |
|   | • Baking tins too large for the recipe.               | - Use correct size tins.  |
|   | • Baking tins not evenly spaced.                      | - Stagger baking tins at least 3cm between tins and the oven walls.         |
|   | • Products not evenly sized or spaced on trays.       | - Make into same size and shape, and spread evenly over trays.              |
|   | • Baking temperature too high.                        | - Lower the temperature.  |
|   | • Food too high in oven.                              | - Cook on shelf lower.  |
| Baked products too brown on bottom                      | • Baking tins too large for the recipe.               | - Use correct size tins.  |
|   | • Baking tins are dark metal or glass.                | - Change to shiny, light tins or lower the temperature by 10°C.             |
|   | • Food too low in the oven.                           | - Cook one shelf higher.  |
|   | • Oven door opened too frequently during baking.      | - Don't open the oven door until at least half the cooking time has passed. |
|   | • Baking temperature too high.                        | - Lower the temperature.  |
| Cakes have a cracked, thick crust                       | • Baking temperature too high.                        | - Lower the temperature.  |
|   | • Food too high in oven.                              | - Cook one shelf lower.   |
|   | • Cake batter over mixed.                             | - Mix just long enough to combine ingredients.                              |
|   | • Pan too deep.                                       | - Check size of pan and use recommended size.                               |
| Baked products are pale, flat and under-cooked          | • Baking pans dark.                                   | - Change to shiny pans.   |
|   | • Baking temperature too high.                        | - Lower the temperature.  |
|   | • Food too low in the oven.                           | - Cook one shelf higher.  |
| Cakes fallen in the centre                              | • Baking time too short.                              | - Increase cooking time.  |
|   | • Incorrect tin size.                                 | - Use correct size tin.   |
|   | • Baking temperature too high.                        | - Lower the temperature.  |
|   | • Proportions of ingredients incorrect in the recipe. | - Check recipe.   |
| Roast meat & potatoes not browning in fan oven          | • Opening door too early in baking.                   | - Do not open the door until the last quarter of cooking time.              |
|   | • Poor hot air circulation.                           | - Elevate food onto a rack to allow air circulation.                        |
| Juices running out of meat                              |   | - Do not pierce meat with fork.   |
|   |   | - Turn with tongs.  |
| Grilled meats overcooked on outside & raw in the centre |   | - Grill at lower shelf position.  |
| Grilled chops & steaks buckling                         |   | - Cut fat with knife towards the meat.                                      |

## OPERATING THE 3 BUTTON PROGRAMMABLE CLOCK

(Where supplied)



### IMPORTANT

Setting the time

If you have purchased a model fitted with an electronic or programmable clock, you **MUST** set the time of day before you can operate your appliance.

Your oven is equipped with a 3 button timer that has the following features:

- Timer - you can set a countdown time that will beep when the set time has elapsed.
- Cook time - you can set cooking duration. A timer will count down the preset cooking time, beep when the time has elapsed and turn the appliance off.
- End time - instead of setting a cooking duration you can set a cooking finish time. When the finish time has been reached the timer will beep and turn the appliance off.
- Delayed start cooking time - you can combine the cooking time and end cooking time to switch oven on and off at a specific time during the day.

### Selecting the timer

- Press the MODE button until the timer 'indicator' begins flashing.
- Set the countdown time you want by using the **-** and **+** buttons. 5 seconds after the last change the timer 'indicator' will stop flashing and the countdown will start in minutes.
- To stop the beeper, press any button.
- Maximum Countdown Time is 2 hours 30 minutes.

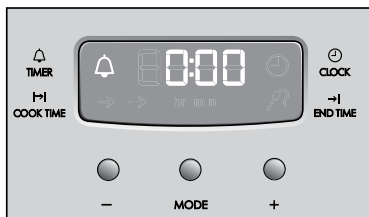

### Setting the cooking duration

- Select the desired oven function and temperature.
- The oven indicator light will glow and the heating source will come on.
- Press the MODE button until the cook time 'indicator' begins flashing.
- Set the cooking duration you want by using the **-** and **+** buttons. Five seconds after the last change the cook time 'indicator' will stop flashing, and the time of day will be displayed.
- To stop beeper, press any button.

*NOTE: Remember to add pre-heating time if necessary.*

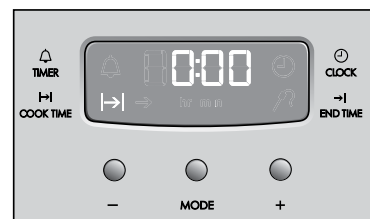

### Setting the cooking end time

- Check that the clock displays the correct time of day.
- Select the desired oven function and temperature. The oven indicator light will glow and the heating source will come on.
- Press MODE button until the end time 'indicator' begins flashing.
- Enter the time of day you want to finish cooking by pressing **-** or **+** buttons. Five seconds after the last change, the end time 'indicator' will stop flashing and the current time of day will be displayed.
- To stop beeper, press any button.

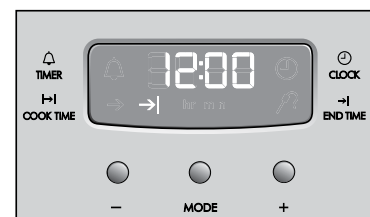

### Setting the delayed start cooking time

- Set the cook time and end time as described in the previous sections.
- Once both the cook time and end time have been set, the cook time and the end time 'indicators' will stop flashing and the current time of day will be displayed.
- To stop beeper, press any button.

## OPERATING THE 120 MINUTE MECHANICAL RINGER TIMER

(Where supplied)

### To check or cancel settings

- To check your settings, press the MODE button until the indicator you want is flashing.
- To cancel "delayed start" press the mode button until a light flashes next to "end time" →|. Press and hold the — button until the clock no longer reverses (you will hear a beep). If you have left the temperature and function knobs at a setting the oven will start once the "end time" →| light stops flashing.
- To cancel "auto shut off" press the mode button until a light flashes next to "cook time" |→|. Press and hold the button until the clock no longer reverses (at 0:00 you will hear a beep). This automatically cancels "delayed start". If you have left the temperature and function knobs at a setting, the oven will start once the "cook time" |→| light stops flashing. Because you have cancelled "auto off" the oven will continue to heat until you manually turn it off.

### On completion of cooking

- The heat source will turn off, the timer will beep and the end time and/or cook time 'indicators' will flash.
- Even though the heating element turns off the oven will still retain substantial heat. This will continue to cook the food until it is removed or the oven cools down. If you do not plan on being present when the oven turns off, you should take this extra heating time into account.
- Turn the function and temperature controls to the off position.
- Press any button to stop the timer beeping.

### Adjusting the clock ⌚

- Press the MODE button until the clock ⌚ 'indicator' begins flashing.
- Press the — or + buttons to change the time of day. 5 seconds after the last change, the clock 'indicator' will disappear, confirming the time has been adjusted.

### Operating your 120 minute ringer timer

To set the timer, simply turn the knob clockwise to the required number of minutes.

*NOTE: For any time below ten minutes, turn the knob past the thirty minute mark, then turn it back to the required number of minutes.*

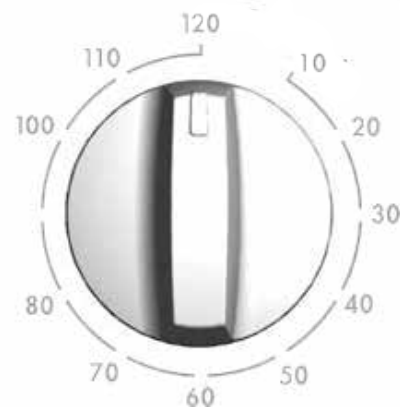



## CLEANING AND CARING FOR THE COOKER



### WARNING

Always make sure that the appliance is turned off before you clean it.

All surfaces should be kept clean to reduce the risk of damage or fire.

### Cleaning Enamel and Glass Door Panels

Keep it clean by wiping it regularly with a soft cloth dipped in warm soapy water. Rub persistent stains vigorously with a creamed powder cleanser.

Note: You can also use household oven enamel cleaners - follow the manufacturer's instructions carefully. Do not use harsh abrasive cleaners, nylon scourers, powder cleaners, steel wool, steam cleaners or wax polishes. Always check manufacturer's recommendations before using their product. When cleaning glass door panels harsh abrasive cleaners and sharp metal scrapers should not be used, as they can scratch the surface and result in premature failure.

### Cleaning your Control Panel

- Make sure control knobs are in the OFF position.
- Clean control panel with a soft damp cloth dipped in warm soapy water.

Do not use excess water when cleaning control panel.

### Cleaning your Hotplates

#### Radiant Hotplates

These hotplates are self-cleaning, so any boil over material will burn to ash and may be wiped away when the hotplate is cold.

The elements are removable so the spillage bowls can be removed for cleaning.



### WARNING

Always make sure that the appliance is turned off before removing the hotplates.

Ensure elements are cold to touch.

- Lift front of element to clear spillage bowl and pull towards you.
- Remove spillage bowl.
- Wash spillage bowl in hot soapy water.

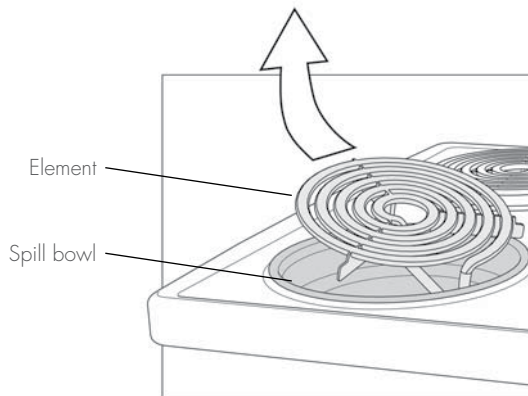

Radiant Hotplate

### Ceramic Hotplates

1. Remove all spilt food and fat with the supplied razor blade scraper, while the ceramic glass is still warm but not hot. Wipe clean with dishwashing detergent on a damp cloth.
2. If aluminium foil, plastic items or high sugar content liquids/foods are allowed to melt on the ceramic glass, these should be removed immediately with the supplied razor blade scraper before the surface has cooled down, otherwise pitting of the surface can occur.

*NOTE: Items with high sugar content not only include jam and fruit, but also vegetables such as peas, tomatoes and carrots. When the ceramic glass is cool wipe clean with dishwashing detergent on a damp cloth.*

3. Do not use abrasive sponges or scourers, as they may scratch the cooktop.
4. Do not use oven sprays or stain removers as these products may also damage the surface.

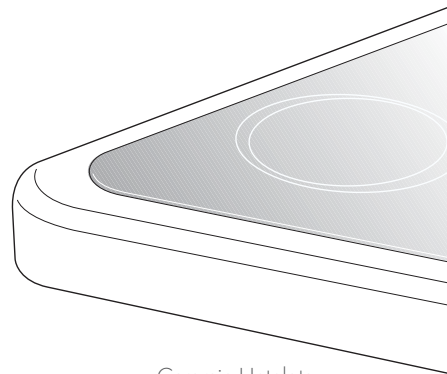

Ceramic Hotplate

## CLEANING AND CARING FOR THE OVEN

### Removing the Oven Shelves

Slide the oven shelves towards you until they reach the front stop. Tilt them up at the front and lift them clear. Wash the shelves in hot soapy water. For heavy baked-on-stains soaking of the shelves may be required. To install the oven shelves, fit the guide between the two side rack rails. This will ensure the shelves remain stable.

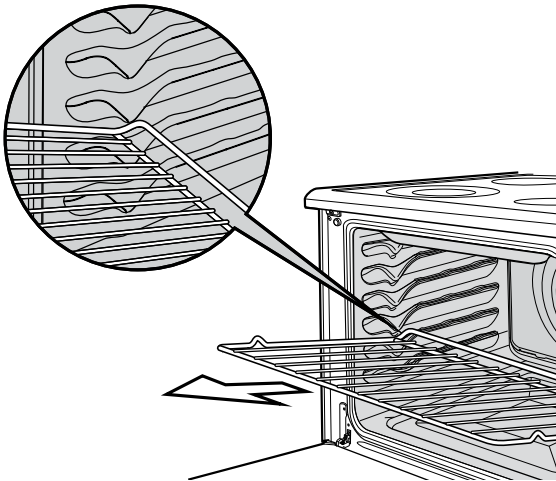

### Replacing the oven light



#### WARNING

Ensure the appliance is switched off at power supply (not just the control knobs) before replacing the light globe to avoid possibility of electric shock.

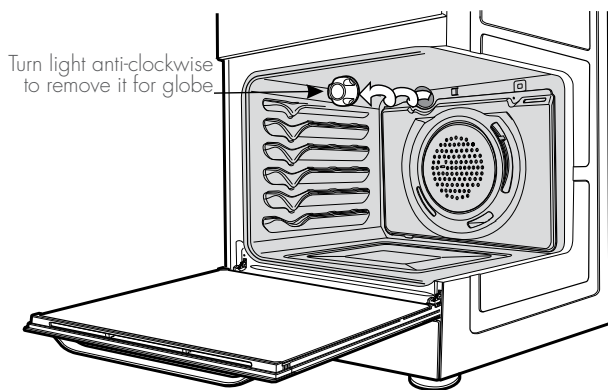

Globe Specifications:  
25W 9maximum/230 – 240V  
Temperature rating 300°C  
Edison screw, small (E14)

### Cleaning



#### WARNING

The cooker can be disengaged and engaged from the anti-tilt bracket for cleaning access. At all other times the cooker **MUST** be engaged onto the anti-tilt bracket.



#### WARNING

The door glass on this appliance is made from tough durable material that withstands heating and cooling without breaking. However it must be remembered that it is glass, it may break. Treat it accordingly! Should you have any questions about the glass in your appliance, please contact the Customer Care Centre by calling 1300 363 640 (Australia) or 0800 436 245 (New Zealand). Do not use harsh cleaners or sharp metal scrapers to clean the oven door since they can scratch the surface, which may result in the shattering of the glass.

### Grill Tray and Grill Pan

Wash the Scone Tray and Grill Dish in hot soapy water.



#### WARNING

Always keep the grill pan clean as any fat left in it may catch fire.

### Grill Compartment

Clean the grill compartment with hot soapy water. If stronger action is needed use a non-abrasive oven cleaner applied with a nylon scourer.

### Warming Drawer



#### WARNING

This compartment will become hot when in use. Do not store flammable components such as aerosols or plastic components in this compartment. Clean the Warming Drawer compartment with hot soapy water.

## CLEANING AND CARING FOR THE COOKER

### Cleaning the oven door

Cool air circulates through the door to lower the surface temperature on the outside of the oven door.



#### CAUTION

- Do not remove the outer oven door. This product has a removable inner glass insert for ease of cleaning.

### To remove the inner door glass for cleaning

- Open the door fully to access the hinges then rotate the "stirrups" on both hinges fully towards the door.

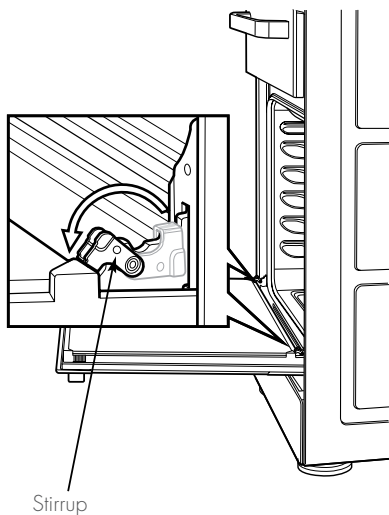

- Slowly close the door until it stops against the 'stirrups'.

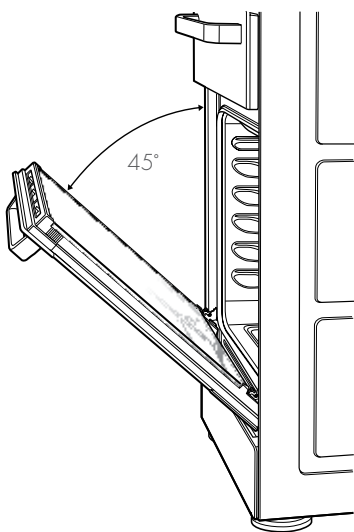

- To remove the top trim, press the ribbed release clips at each end and lift top trim away from the door.

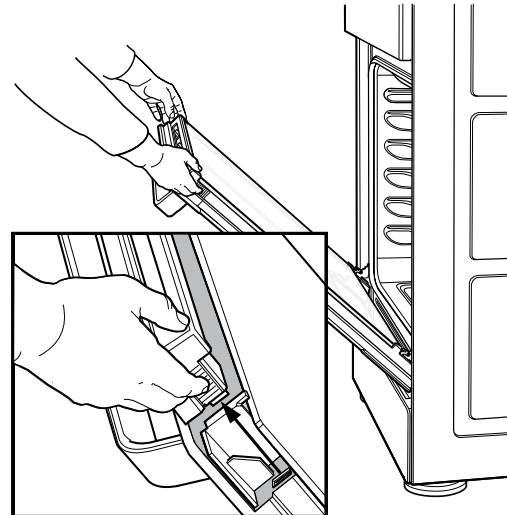

- Using both hands, gently remove the inner glass by sliding out and lifting away from the door.

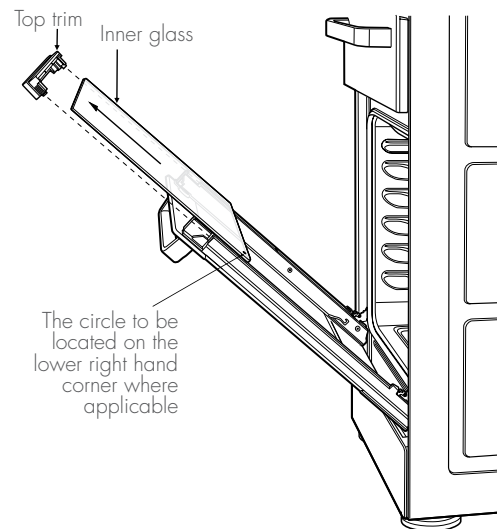

- Hand wash only with a soft cloth and warm soapy water. When dry, polish with a soft cloth and ensure the glass is dry before re-assembly.
- Wipe inner and outer glass gently with detergent and warm water.
- Wipe clean and dry thoroughly.

## CLEANING AND CARING FOR THE OVEN

### Re-assembling the oven door inner glass

- When replacing the door inner glass, make sure the circle is positioned as shown in the image (where applicable).
- Replace the top trim ensuring the clips snap back into position.
- Fully open the door, rotate the stirrups back to their original position and close the door.



#### WARNING

- DO NOT use the oven without the inner glass fitted.
- DO NOT use harsh abrasives on glass as this may damage the glass.
- DO NOT place glass in dishwasher.

### Safety warnings about cleaning



#### WARNING

- ALWAYS make sure that the cooker is turned off before cleaning.



#### CAUTION

- ALWAYS clean cooker immediately after use.
- DO NOT use steam cleaners. These may cause moisture build-up, especially in the glass door.
- DO NOT use caustic based cleaners or harsh abrasives, these will damage your oven.

### Door glass

- DO NOT use harsh abrasive cleaners or sharp metal scrapers to clean glass since they can scratch the surface, which may result in shattering of the glass.

## INSTALLATION

### Removing the oven door

(To be done by qualified personnel only)

1. With door fully open, rotate the two stirrups to its rest position.

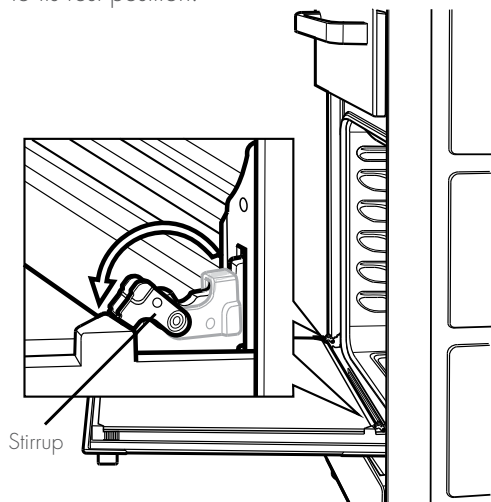

2. Close the door until it stops against the stirrups.

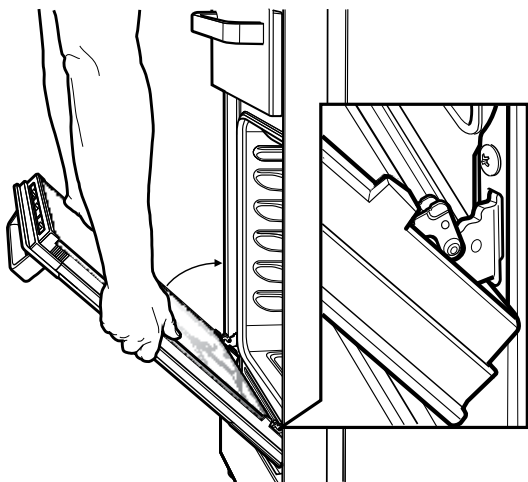

3. Close the door further.

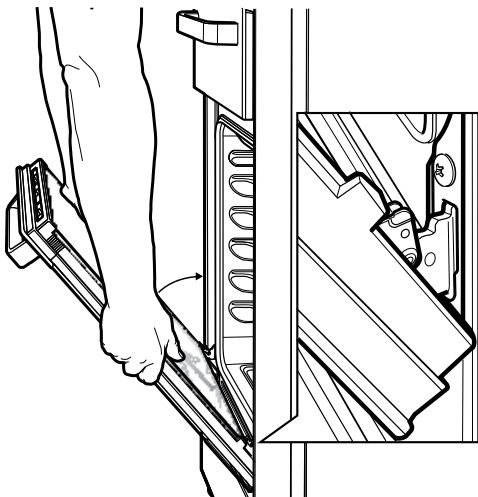

4. Lift the door slightly and evenly while continuing to slowly close the door.

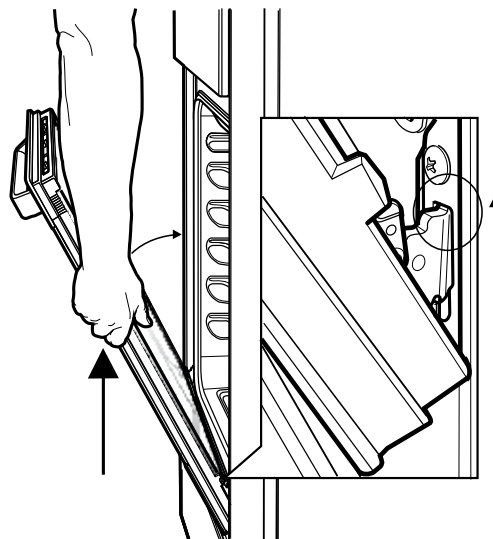

5. Remove the door by lowering gently and pull away from the frame of the oven. Care should be taken not to damage kick panel and other parts of the cooker.

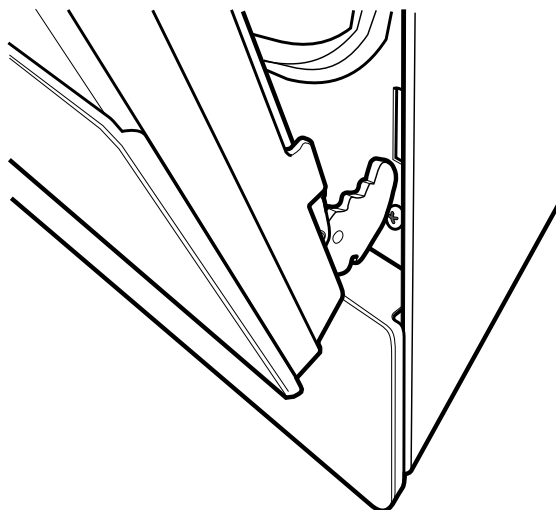

## INSTALLATION

### Replacing the oven door

(To be done by qualified personnel only)

1. Hold door with both hands.
2. Locate both hinges into the frame slots at the same time.

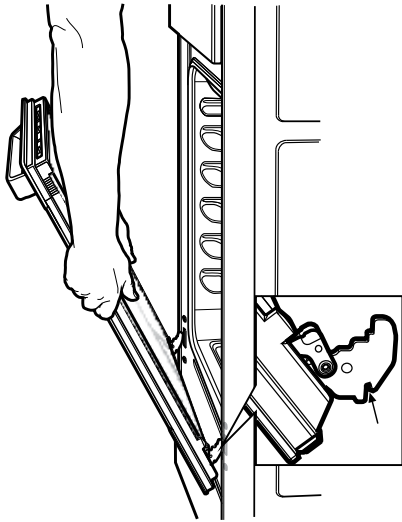

3. Ensure that the location notch drops into frame slot. Care should be taken not to damage other parts of the cooker.

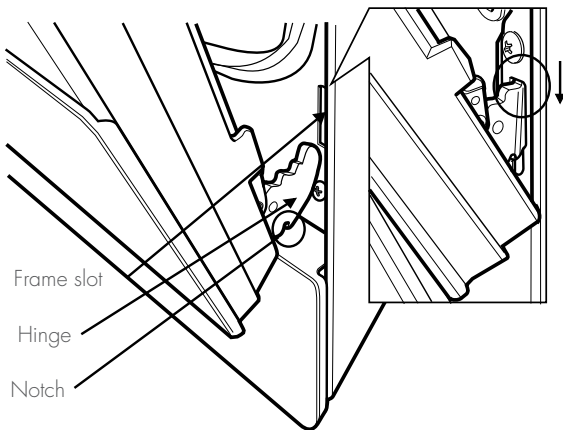

4. Open door fully and rotate stirrups away from you, and back to their original position.

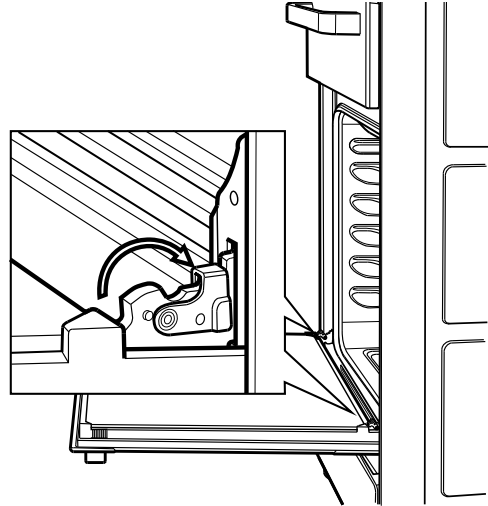

5. Close the door fully.

### Service fuse location – models with powerpoint only

This product is fitted with a power outlet at each end of the control panel. The outlets are protected by a replaceable high breaking capacity 15 amp fuse located at the rear of the product.



### WARNING

Before servicing the fuse, ensure that all power to product is switched off.

To access fuse, unscrew fuse housing and remove from appliance. (See diagram).

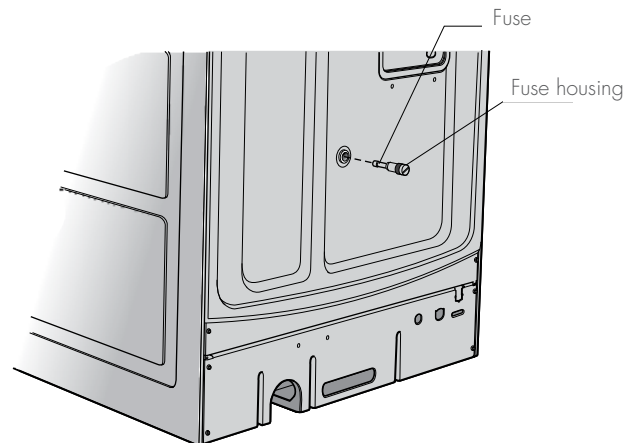

## SOLVING PROBLEMS

### Faults

If you have a problem with your oven and/or grill, please:

- Check the points listed below before calling for service. You may be able to avoid a service call by fixing the problem yourself - and so continue cooking.

*NOTE: We may charge you for service even in the guarantee period if your problem is due to the causes listed below.*

### Data Plate

When you need information, service or replacement parts please:

- Quote the: 1 Model; 2 Model Number & 3 Serial Number.

You can find these on the data plate which is at the bottom of the oven front. The data plate is visible when the door is open.

If you need more information, please contact the **Customer Care Centre** on **1300 363 640**

(Australia – Centre is open 8.00am – 5.00pm Monday to Friday Eastern Standard Time)

or **0800 436 245** (New Zealand – Centre is open 8.00am – 5.00pm Monday to Friday).

If you have a warranty or spare parts enquiry, you should call the number listed on the back page.

| PROBLEM                      | POSSIBLE CAUSES  |
|------------------------------|--|
| Oven or grill not working    | Electronic clock has not been set.<br>Power not turned on.<br>Controls or clock are incorrectly set.<br>Household fuse has blown or power supply is off.<br><i>NOTE: If the household fuse continues to blow, call the Service Centre.</i> |
| Oven light not working       | Lamp blown or loose in socket.<br>Household fuse has blown or power supply is off.<br><i>NOTE: If the household fuse continues to blow, call the Service Centre.</i>   |
| Oven not heating enough      | Foil or trays on bottom of oven. REMOVE IMMEDIATELY.   |
| Oven not working             | Electronic clock has not been set.<br>Clock is in Auto mode. (Refer to operating instructions).<br>Household fuse has blown or power supply is off.<br><i>NOTE: If the household fuse continues to blow, call the Service Centre.</i>      |
| Timer flashing on display    | Electronic clock has not been set.<br>Power failure or interruption.<br>Household fuse has blown or power supply is off.<br><i>NOTE: If the household fuse continues to blow, call the Service Centre.</i>                                 |
| Unit smoking when first used | Protective oils being removed. This is normal conditioning of the oven on first use.   |
| Condensation building up     | Reduce the amount of water used in cooking.  |
| Odours on first use of oven  | This is normal conditioning of the oven insulation for the first 30 minutes.   |
| Power points not working     | Fuse at rear has blown.  |

*NOTE: Only authorised service centres should carry out servicing. Otherwise warranty may be void.*



**This document sets out the terms and conditions of the product warranties for Electrolux Appliances. It is an important document. Please keep it with your proof of purchase documents in a safe place for future reference should you require service for your Appliance.**



1. In this warranty:
  - (a) 'acceptable quality' as referred to in clause 10 of this warranty has the same meaning referred to in the ACL;
  - (b) 'ACL' means Schedule 2 to the Competition and Consumer Act 2010;
  - (c) 'Appliance' means any Electrolux product purchased by you and accompanied by this document;
  - (d) 'ASC' means Electrolux authorised service centres;
  - (e) 'Electrolux' means Electrolux Home Products Pty Ltd of 163 O'Riordan Street, Mascot NSW 2020, ABN 51 004 762 341 in respect of Appliances purchased in Australia and Electrolux (NZ) Limited (collectively 'Electrolux') of 3-5 Niall Burgess Road, Mount Wellington, in respect of Appliances purchased in New Zealand;
  - (f) 'major failure' as referred to in clause 10 of this warranty has the same meaning referred to in the ACL and includes a situation when an Appliance cannot be repaired or it is uneconomic for Electrolux, at its discretion, to repair an Appliance during the Warranty Period;
  - (g) 'Warranty Period' means the Appliance is warranted against manufacturing defects in Australia for 24 months and in New Zealand for 24 months, following the date of original purchase of the Appliance;
  - (h) 'you' means the purchaser of the Appliance not having purchased the Appliance for re-sale, and 'your' has a corresponding meaning.
2. This warranty only applies to Appliances purchased and used in Australia or New Zealand and used in normal domestic applications and is in addition to (and does not exclude, restrict, or modify in any way) any non-excludable statutory warranties in Australia or New Zealand.
3. During the Warranty Period Electrolux or its ASC will, at no extra charge if your Appliance is readily accessible for service, without special equipment and subject to these terms and conditions, repair or replace any parts which it considers to be defective. Electrolux or its ASC may use remanufactured parts to repair your Appliance. You agree that any replaced Appliances or parts become the property of Electrolux. This warranty does not apply to light globes, batteries, filters or similar perishable parts.
4. Parts and Appliances not supplied by Electrolux are not covered by this warranty.
5. To the extent permitted by law, you will bear the cost of transportation, travel and delivery of the Appliance to and from Electrolux or its ASC. If you reside outside of the service area, you will bear the cost of:
  - (a) travel of an authorised representative;
  - (b) transportation and delivery of the Appliance to and from Electrolux or its ASC.

In all instances, unless the Appliance is transported by Electrolux or an Electrolux authorised representative, the Appliance is transported at the owner's cost and risk while in transit to and from Electrolux or its ASC.
6. Proof of purchase is required before you can make a claim under this warranty.

7. You may not make a claim under this warranty unless the defect claimed is due to faulty or defective parts or workmanship. Electrolux is not liable in the following situations (which are not exhaustive):
  - (a) the Appliance is damaged by:
    - (i) accident
    - (ii) misuse or abuse, including failure to properly maintain or service
    - (iii) normal wear and tear
    - (iv) power surges, electrical storm damage or incorrect power supply
    - (v) incomplete or improper installation
    - (vi) incorrect, improper or inappropriate operation
    - (vii) insect or vermin infestation
    - (viii) failure to comply with any additional instructions supplied with the Appliance;
  - (b) the Appliance is modified without authority from Electrolux in writing;
  - (c) the Appliance's serial number or warranty seal has been removed or defaced;
  - (d) the Appliance was serviced or repaired by anyone other than Electrolux, an authorised repairer or ASC.
8. This warranty, the contract to which it relates and the relationship between you and Electrolux are governed by the law applicable where the Appliance was purchased. Where the Appliance was purchased in New Zealand for commercial purposes the Consumer Guarantee Act does not apply.
9. To the extent permitted by law and subject to your non-excludable statutory rights and warranties, Electrolux excludes all warranties and liabilities (other than as contained in this document) including liability for any loss or damage whether direct or indirect arising from your purchase, use or non use of the Appliance.
10. For Appliances and services provided by Electrolux in Australia, the Appliances come with a guarantee by Electrolux that cannot be excluded under the ACL. You are entitled to a replacement or refund for a major failure and for compensation for any other reasonably foreseeable loss or damage. You are also entitled to have the Appliance repaired or replaced if the Appliance fails to be of acceptable quality and the failure does not amount to a major failure. The benefits to you given by this warranty are in addition to your other rights and remedies under a law in relation to the Appliances or services to which the warranty relates.
11. At all times during the Warranty Period, Electrolux shall, at its discretion, determine whether repair, replacement or refund will apply if an Appliance has a valid warranty claim applicable to it.
12. For Appliances and services provided by Electrolux in New Zealand, the Appliances come with a guarantee by Electrolux pursuant to the provisions of the Consumer Guarantees Act, the Sale of Goods Act and the Fair Trading Act.
13. To enquire about claiming under this warranty, please follow these steps:
  - (a) carefully check the operating instructions, user manual and the terms of this warranty;
  - (b) have the model and serial number of the Appliance available;
  - (c) have the proof of purchase (e.g. an invoice) available;
  - (d) telephone the numbers shown below.
14. You accept that if you make a warranty claim, Electrolux and its ASC may exchange information in relation to you to enable Electrolux to meet its obligations under this warranty.

### Important Notice

Before calling for service, please ensure that the steps listed in clause 13 above have been followed.

|   |   |   |
|---|---|---|
| <p><b>FOR SERVICE</b><br/>                     or to find the address of your nearest state service centre in Australia<br/> <b>PLEASE CALL 13 13 49</b><br/>                     For the cost of a local call (Australia only)</p> | <p><b>SERVICE AUSTRALIA</b><br/>  <b>Electrolux</b><br/>                     ELECTROLUX HOME PRODUCTS<br/>                     electrolux.com.au</p> | <p><b>FOR SPARE PARTS</b><br/>                     or to find the address of your nearest state spare parts centre in Australia<br/> <b>PLEASE CALL 13 13 50</b><br/>                     For the cost of a local call (Australia only)</p> |
| <p><b>FOR SERVICE</b><br/>                     or to find the address of your nearest authorised service centre in New Zealand<br/> <b>FREE CALL 0800 10 66 10</b><br/>                     (New Zealand only)</p>                  | <p><b>SERVICE NEW ZEALAND</b><br/>  <b>Electrolux</b><br/>                     ELECTROLUX (NZ) Limited<br/>                     electrolux.co.nz</p> | <p><b>FOR SPARE PARTS</b><br/>                     or to find the address of your nearest state spare parts centre in New Zealand<br/> <b>FREE CALL 0800 10 66 20</b><br/>                     (New Zealand only)</p>                       |





For more information on all Westinghouse appliances,  
or for dimension and installation information, call into your retailer,  
phone or email our customer care team or visit our website:

#### AUSTRALIA

phone: 1300 363 640  
fax: 1800 350 067  
email: [customercare@electrolux.com.au](mailto:customercare@electrolux.com.au)  
web: [westinghouse.com.au](http://westinghouse.com.au)

#### NEW ZEALAND

phone: 0800 436 245  
fax: 0800 363 600  
email: [customercare@electrolux.co.nz](mailto:customercare@electrolux.co.nz)  
web: [westinghouse.co.nz](http://westinghouse.co.nz)

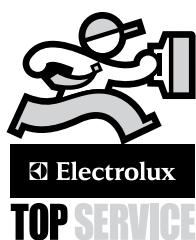

#### TOP SERVICE

Top Service encompasses the after sales service provided by The Electrolux Group to consumers including delivery, home service and spare parts.

**Westinghouse. We are part of the Electrolux family.**  
Share more of our thinking at [electrolux.com](http://electrolux.com)

**Part No. 0342 001 617 Rev 003 ECN no. : 048408D**

© 2015 Electrolux Home Products Pty Ltd. ABN 51 004 762 341  
WMAN\_ECOOK\_Jul15

